

Grille on Plenum

The ProAirKit Systems are specifically designed for Hotel rooms. This is the most comprehensive air solution on the market, designed to prevent condensation.

This package includes a grille, a plenum box and installation instructions. The product is not assembled. Manufactured in standard sizes.

The product is only installed on 12.5mm thickness gypsum boards.

PAK700



1 Slot 40mm			
Q(m3/h)	V(m/s)	T(m)	Noise(db)
340	2.55	3.22	20
400	3	3.88	20
500	3.8	4.95	23

PAK1000

1 Slot 50mm			
Q(m3/h)	V(m/s)	T(m)	Noise(db)
400	2.5	3.2	20
500	3	4.95	22
650	3.8	5.85	25



2 Slot 25mm			
Q(m3/h)	V(m/s)	T(m)	Noise(db)
400	2.55	1.56	22
490	3	2.02	25
610	3.8	2.8	27

2 Slot 30mm			
Q(m3/h)	V(m/s)	T(m)	Noise(db)
480	2.55	0.9	22
580	3	1.4	25
720	3.8	2.15	27



3 Slot 20mm			
Q(m3/h)	V(m/s)	T(m)	Noise(db)
480	2.55	1.45	25
580	3	1.85	27
720	3.8	2.55	31

3 Slot 25mm			
Q(m3/h)	V(m/s)	T(m)	Noise(db)
540	2.55	1.45	25
640	3	1.91	27
800	3.8	2.75	32



Linear C 8-5/ Height 150mm			
Q(m3/h)	V(m/s)	T(m)	Noise(db)
550	2.5	3.8	22
650	3	4.45	25
820	3.8	5.6	29

Linear C 12-5/ Height 200mm			
Q(m3/h)	V(m/s)	T(m)	Noise(db)
900	2.5	4.8	23
1100	3	5.85	27
1350	3.8	7.2	30

The package includes the following parts:

a GRILLE



b PLENUM BOX PARTS

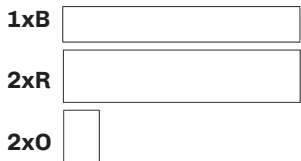

c ALIGNED SUPPORT

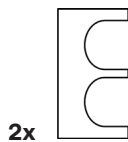

d ASSEMBLY & INSTALLATION SCREWS 35mm



40x

e VENTUS SPIGOTS

NOT INCLUDED

Can be purchased separately



1 ASSEMBLY INSTRUCTIONS

Step 1

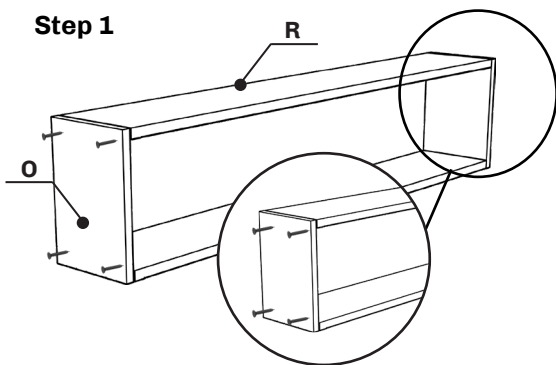

Step 2

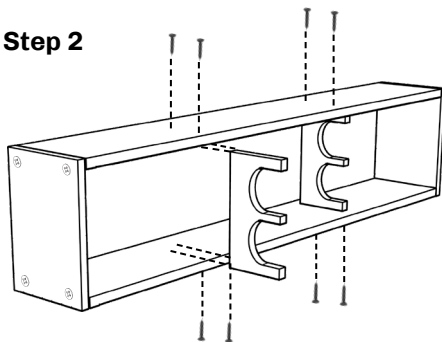

Step 3

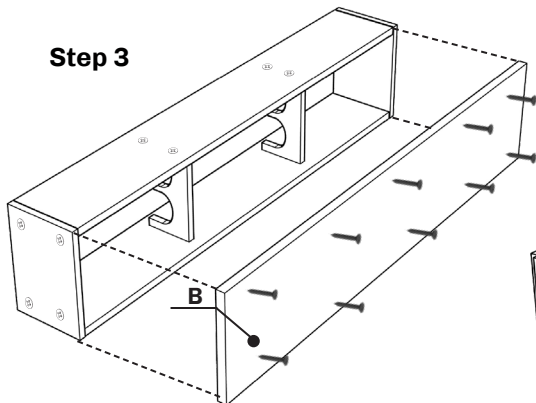

Step 4

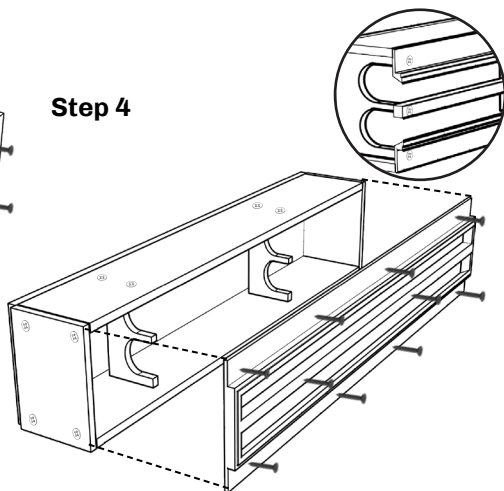

2

INSTALLATION PROCESS

Step 1

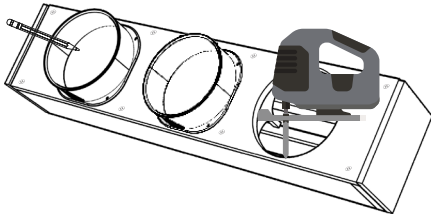

Step 2

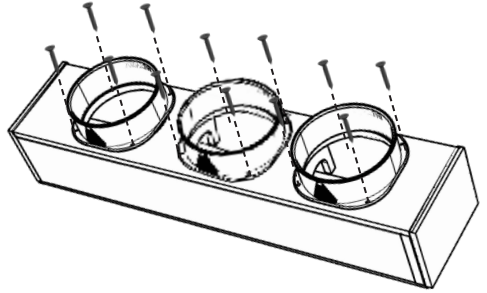

Gypsum board

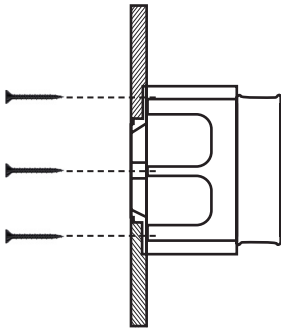

Gypsum board

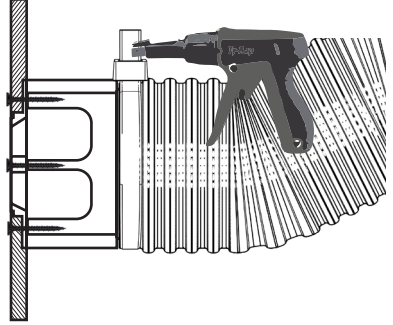

3

FINISHING PROCESS

Step 1

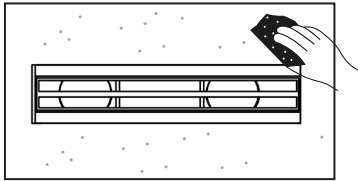

Step 2

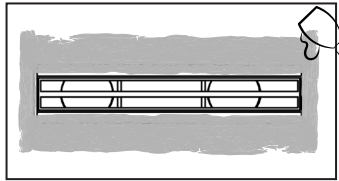

Step 3

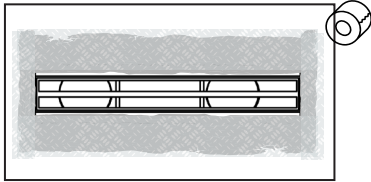

Step 4

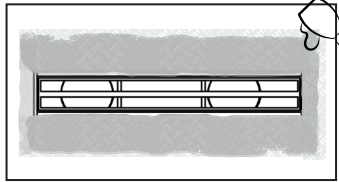

Step 5

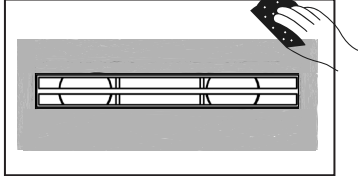

Step 6

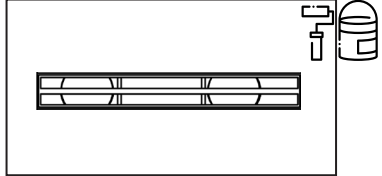

DISASSEMBLY INSTRUCTIONS

Step 1

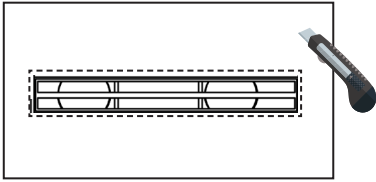

Step 2

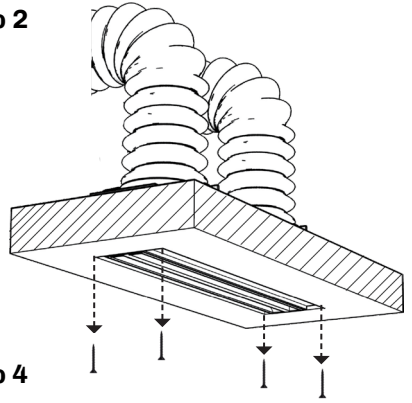

Step 3

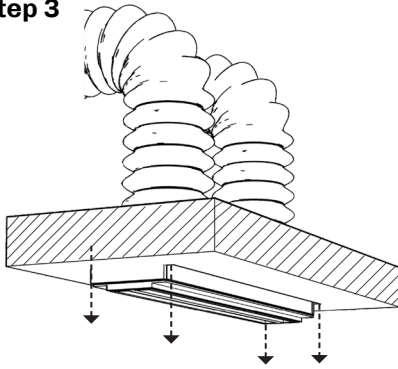

Step 4

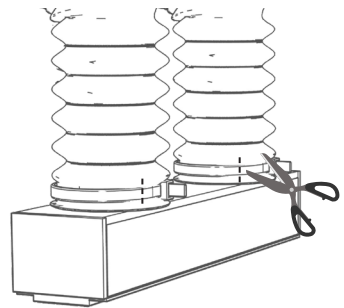

Step 5

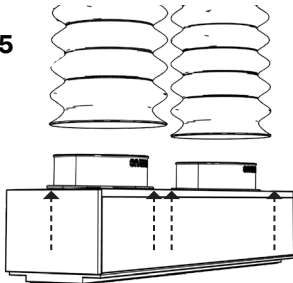

Step 6

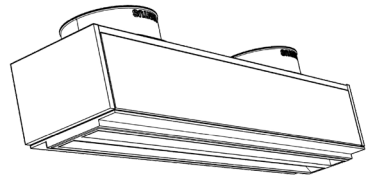

Give Your Product a New Life!

All D.Ellinas products are designed to be disassembled for either reuse or recycling.

www.proairkit.com

Copyright © Proairkit® is a brand of D.Ellinas Factory Products Ltd®, protected by European and International laws pertaining to intellectual property.

D.Ellinas Factory Products is a registered company in Cyprus (reg. no. HE2603755)